

HMF 1244-Z



- power to lift.

HMF Grab Loader 1244-Z

A sturdy B4 rated Grab Loader for rough Working

- Modern design offering very compact installation with long reach.
- Low tare weight offering improved vehicle payload.
- Well suited to many different purposes thanks to optimized boom geometry.
- Reliable and sturdy design.
- Simple and user-friendly RCL Safety System.
- Ergonomically designed operator platforms for easy operation and access.
- High speed operation ensures optimal performance.
- Efficient protection of hydraulic hoses.
- Available with radio remote control or top seat as optional extras.
- Available with one or two hydraulic extensions.

Loading group B4		1244-Z1	1244-Z2
Load moment	tm	10.7	10.3
Hydraulic reach	m	6.7	8.3
Slewing torque	kgm	2400	2400
Slewing angle	°	400	400
Height above chassis	mm	2258	2290
Height above chassis, parked in body min.	mm	2200	2200
Width, folded	mm	2500	2500
Length incl. extra valves	mm	750	750
Stabilizer spread, standard	mm	3500	3500
Stabilizer spread, double extension	mm	4600	4600
Weight, excl. stabilizers	kg	1530	1640
Weight of stabilizers, standard	kg	210	210
Working pressure	MPa	28.0	28.0
Pump performance	l/min	1x60/2x50	
Power consumption	kW	28/47	
Oil tank capacity, separate tank	l	90-160	

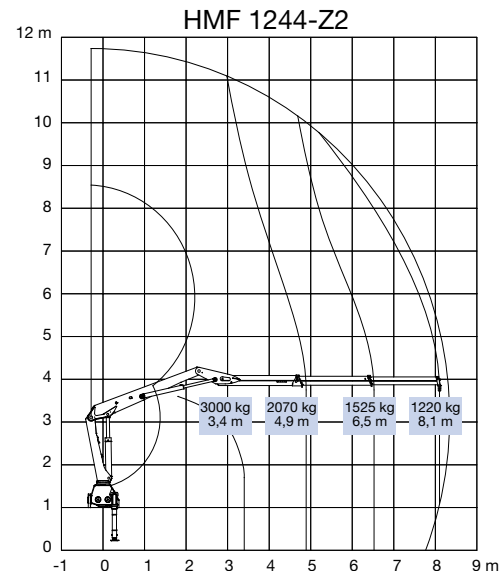
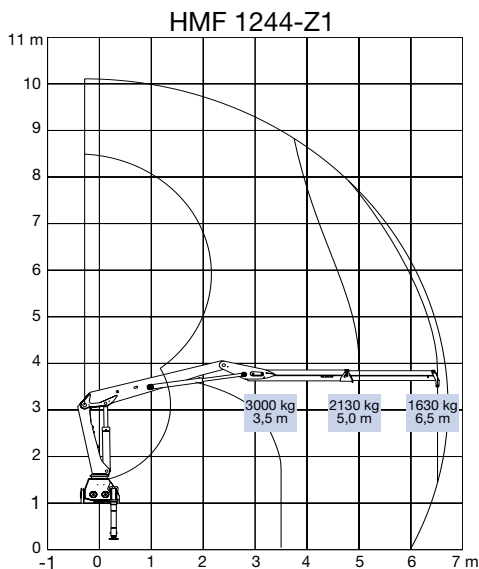

HMF 1244-Z1

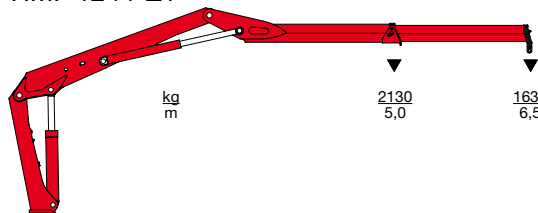

HMF 1244-Z2

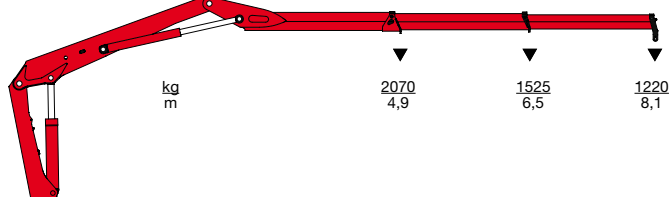

HMF 1244-Z2

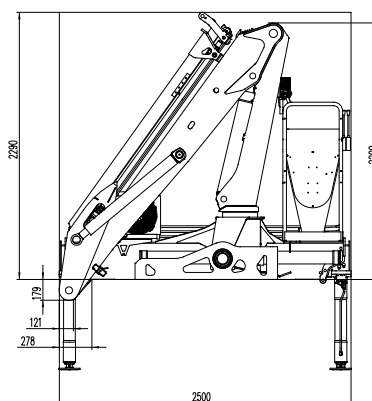

HMF 1244-ZC

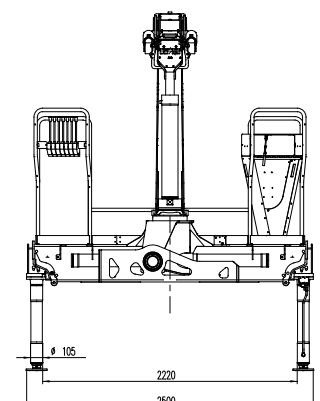

Z008000-7



Højbjerg Maskinfabrik A/S • Oddervej 200 • DK-8270 Højbjerg
Tel.: +45 8627 0800 • Fax: +45 8627 0744 • info@hmf.dk

www.hmf.dk

We reserve the right to introduce improvements and modifications