

# HMF 1110-K



- power to lift.

# HMF Knuckle Boom Loader 1110-K

## A sturdy and efficient Loader in the 11 tm Range

- The HMF 1110-K Series is a simply designed compact loader with user-friendly operation.
- The 1110-K is a B3 rated loader optimized for heavy duty grab work and stone handling – a strong working tool for professional use.
- The loader series is equipped with a link arm system on the loader column which ensures good close-range lifting performances combined with high lifting capacity at a long reach.
- The 1110-K is available with a wide range of operation options including; ground control, radio remote control, stand-up control and top seat control.
- Supplied with the RCL Safety System as standard, which constantly monitors loader operating conditions such as load moment, operation and function. This ensures loader safety whilst the operator concentrates on lifting.
- Can be specified with 2-stage LMB or EVS safety systems, which allow the operator to concentrate on difficult lifting tasks whilst ensuring the vehicle remains stable.
- The loader series is available with a wide range of optional extras including: manual extensions, oil cooler, spotlight and height indicator.

Loading group B3		1110-K1	1110-K2	1110-K3	1110-K4
Load moment	tm	10,5	10,3	9,9	9,5
Hydraulic reach	m	6,2	8,0	10,0	11,9
Slewing torque	kgm	1730	1730	1730	1730
Slewing angle	°	400	400	400	400
Height above chassis	mm	2187	2187	2187	2187
Width, folded	mm	2400	2400	2450	2472
Length of base, no extra valves	mm	755	755	755	755
Length of base with extra valves	mm	860	860	860	-
Stabilizer spread, standard	mm	5000	5000	5000	5000
Stabilizer spread, double extension	mm	6000	6000	6000	6000
Weight excl. stabilizers	kg	1320	1435	1550	1660
Weight of stabilizers, standard	kg	200	200	200	200
Working pressure	MPa	26,5	26,5	26,5	26,5
Pump performance	l/min	50	50	40	40
Oil tank capacity, separate tank	l	65	65	65	65
Power consumption	kW	22	22	18	18

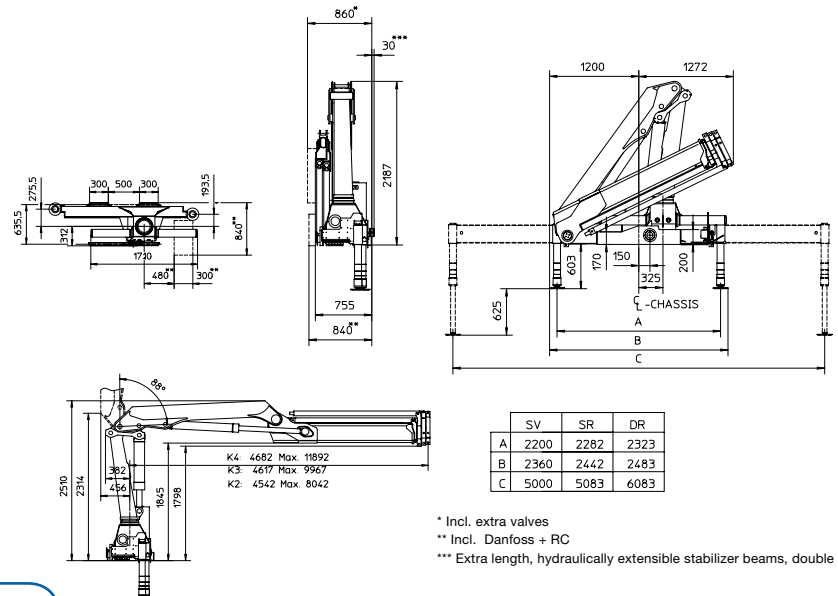
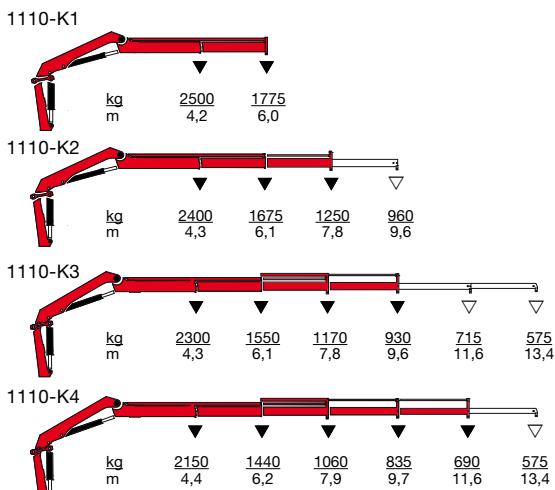
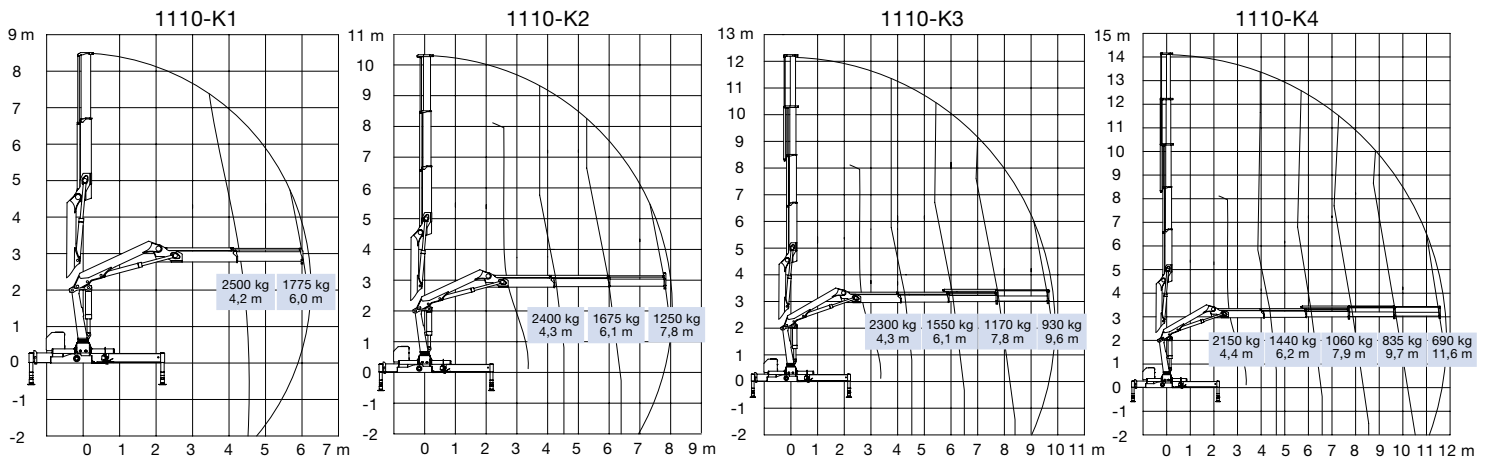

Z008125-1

We reserve the right to introduce improvements and modifications



Højbjerg Maskinfabrik A/S • Oddervej 200 • DK-8270 Højbjerg  
 Tel.: +45 8627 0800 • Fax: +45 8627 0744 • info@hmf.dk

www.hmf.dk